



POLEKS MAKİNA SAN.VE TİC.AŞ

2.Organize San. Bol. Yalçak Cad. Işıktepe Sk. No:21
Konya / TURKEY

www.poleks.com.tr poleks@poleks.com.tr

Tel: +90 332 239 00 11 Fax: +90 332 239 02 59



Follow Next Pages

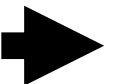



POLEKS MAKİNA SAN. VE TİC.AŞ.

2.Organize San. Bol. Yaylacik Cad. İşiktepe Sk. No:21 Konya / TURKEY

www.poleks.com.tr poleks@poleks.com.tr

Tel: +90 332 239 00 11 Fax: +90 332 239 02 59

- *Cast-iron body*
- *(CBN diamond & Segmental Wheel) cutting technology.*
- *Transmission head, up and down movements with speed adjustable*
- *Electronic speed adjustable spindle rotation motor,*
- *Electronic speed adjustable Table Movement(X axis) Speed Adjustable*
- *Table movement (X axis) Ball Screw and Reducer Power*
- *Movable control panel,*
- *Speed adjustable table for surface grinding process*
- *Wheel dressing device fixed on grinding head(angle device)*
- *Sliding cover system(CE standards)*
- *Transmission down and up movements with ball screw and automatic lubrication*
- *Table slides 'Linear Guides ' with automatic lubrication system(X,Z axis)*
- *Time setting Automatic Lubrication System for all slides and ball screws(Z,X axis)*
- *4 Tons table weight load capacity*
- *Slides automatic lubrication system(Z,X axis)*
- *Grinding wheel rotation Speed adjustable*
- *Electric panel inside lighting lamp*





POLEKS MAKİNA SAN. VE TİC.AŞ.

2.Organize San. Bol. Yaylacik Cad. İşiktepe Sk. No:21 Konya / TURKEY

www.poleks.com.tr poleks@poleks.com.tr

Tel: +90 332 239 00 11 Fax: +90 332 239 02 59

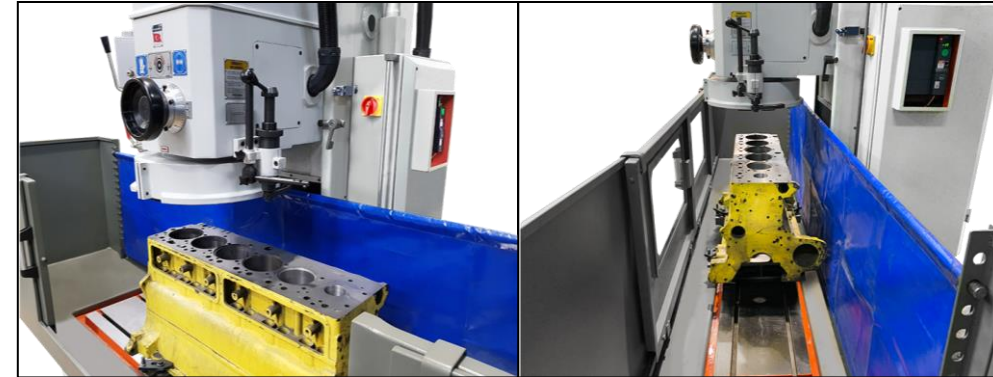

Technical Specifications		YT 1200
Machine table surface	Mm	1300x300
Max. Grinding length(-X axis)	Mm	1200
Max. Grinding width(-Y axis)	Mm	300
Distance between column guides and table center	Mm	400
Max.Distance from wheel to table surface	Mm	600
Max/Min. Table speed (-X axis)	m/min	0-8000
Manual feed movement (-Z axis)	Mm	0.01
Segmental grinding wheel diameter(max)	Mm	350
Grinding wheel rotation speed	Rpm	1-4000
Electric system	V	380-24
Stroke motor (Z)	Kw	0.37
Table motor (X)	Kw	1.1
Spindle motor	Kw	2.9
Cooling unit pump motor	Kw	0.37
Work length of machine	Mm	4000
Length of machine	Mm	2530
Width of machine	Mm	1305
Height of machine	Mm	2020
Weight of machine	Kg	1925



POLEKS MAKİNA SAN. VE TİC.AŞ.

2.Organize San. Bol. Yaylacik Cad. İşiktepe Sk. No:21 Konya / TURKEY

www.poleks.com.tr poleks@poleks.com.tr

Tel: +90 332 239 00 11 Fax: +90 332 239 02 59

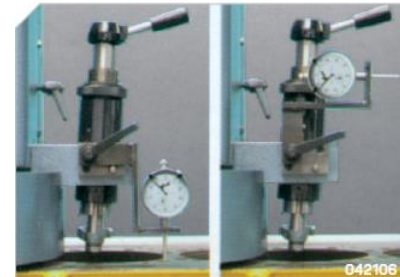
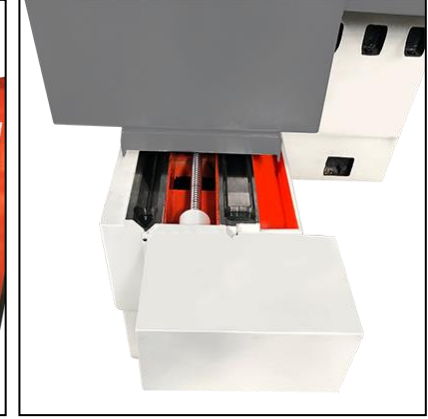

Taş tarama aparatı ve paso saati (saat ekstra)
Wheel dresser and feed indicator (dial gauge extra)

Paso verme ve taş bileme aparatı
Precision incremental in feed
and wheel grinding apparatus

Seri No	Standard Extra Equipments	YT 1200
042100	Segmental wheel diam. 400 mm complete with 10 grinding segments	1
042102	Grinding wheel balancing shaft	1
042103	Toolholder complete with tool for the milling of cast iron and aluminium	1
042104	Automatic device for rapid lifting and lowering of head	1
042105	Automatic device for machine stop after cutting	1
042106	Segmental wheel dressing apparatus	1
042107	Set of two parallel supports 100x535 mm	2
042108	Clamping plates	4
042110	Cooling unit	1
042111	Instruction manual	Extra
042112	Magnetic Table	Extra
042113	Magnetic cooling water separator	Extra



042107

Paralel ayaklar
Parallels supports



042102

Balans aparatı
Grinding wheel
balancing shaft



042100

Taşlama diskli
Surface grinding disk.



042103

Yüzey tarama aparatı
Surface milling apparatus.

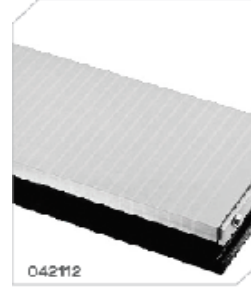

042112

Manyetik tabla (ekstra)
Magnetic table (extra)

042108



POLEKS MAKİNA SAN. VE TİC.AŞ.

2.Organize San. Bol. Yaylacik Cad. İşiktepe Sk. No:21 Konya / TURKEY

www.poleks.com.tr poleks@poleks.com.tr

Tel: +90 332 239 00 11 Fax: +90 332 239 02 59

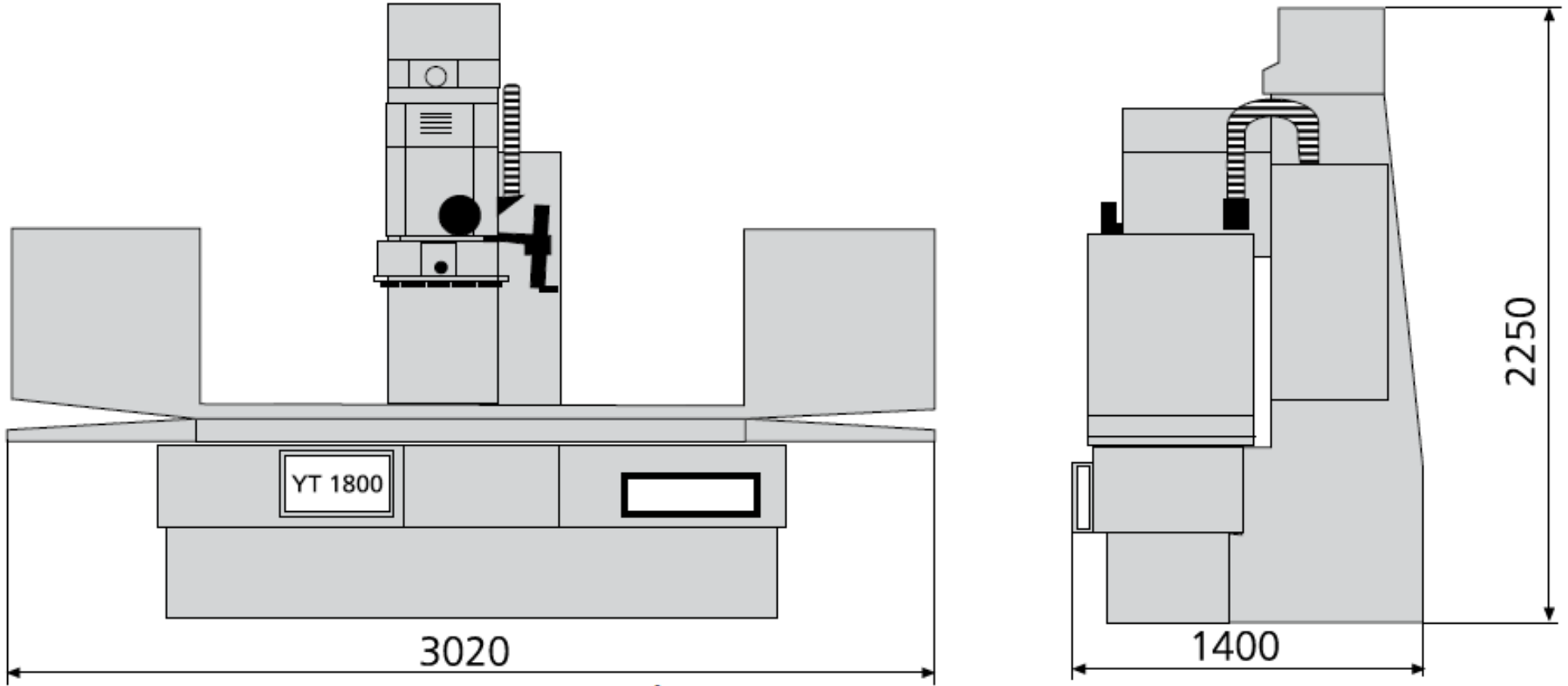

GTİP No: 8460.19.00.00.00